

TECHNICAL GUIDANCE DOCUMENT

SPACELOFT AEROGEL BLANKET INSULATION

BASED ON ETA – 11_0471 – ISSUE 21

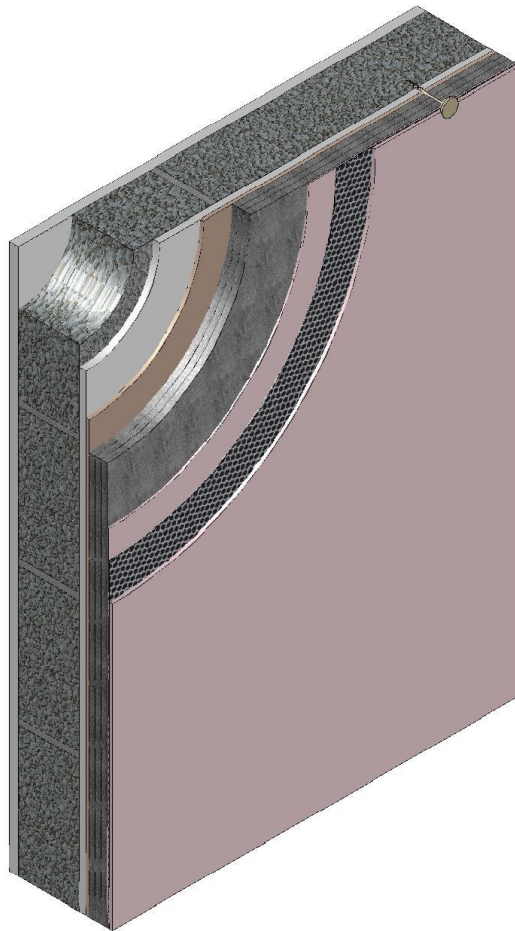

ASPEN AEROGELS, INC.

30 FORBES ROAD, BUILDING B
NORTHBOROUGH, MA 01532

USA

TEL: 1.508.691.1111

INFO@AEROGEL.COM

1. Product Description

Spaceloft® aerogel blanket is an ultra-high performance fibre reinforced silica aerogel blanket insulation suitable for thermal performance upgrades of solid walls, floors and roofs and associated thermal bridges in new, recent & historic buildings.

Spaceloft® uses the insulating power of air trapped in a nano-porous foam matrix to deliver its excellent thermal performance.

Spaceloft® does not rely on a vacuum or heavy molecular gasses to insulate.

Spaceloft® is hydrophobic, water vapour permeable but non-hygroscopic and does not provide a capillary transport mechanism for liquid water.

Spaceloft® is manufactured in roll form, 5mm or 10mm thick, 1.45m wide - approximately 65m² per roll. **Spaceloft**® is usually applied in the form of a factory laminated composite panel but it can also be used in direct application methods.

Spaceloft® carries a European Technical Approval (ETA) governing its use as a thermal insulation in various Building & Construction applications - ETA 11_0471.

2. Application Suitability

Spaceloft® provides a highly effective method of reducing heat loss through walls, floors, roofs and at thermal bridge junctions.

Spaceloft® will limit the risk of surface condensation however the risk of interstitial condensation should also be assessed by means of an appropriate diagnostic tool.

3. Physical Characteristics

To ensure that **Spaceloft**® is applied in an appropriate manner Aspen Aerogels has compiled a comprehensive database of physical and hygro-thermal properties. A **Spaceloft**® material file is

available on request for common hygro-thermal simulation software programs – example WUFI.

3.1. Basic Physical Properties

Property	Value	Unit
Density	150	kgs / m ³
Thermal Conductivity	0.015	W/mK
Colour	Grey or White	
Fire Class	C-s1-d0	
Compressive Strength	80	kPa@10%
Embodied energy	5.4	kgs or CO ₂ per m ² (10mm)
pH	8	
Nominal Thickness	5 & 10	mm
Form	Fibre Reinforced Aerogel Blanket	
Width	~1.45*	m

* Approximate figure - blanket widths can vary – refer to Declaration of Performance SL2013-01 for blanket length, width & thickness tolerances.

3.2. Hygro-Thermal Properties

Property	Value	Unit
Specific heat Capacity	1000	J/kg/K
Vapour Permeability Factor (23-0/50)	4.7	Mu
Vapour Permeability Factor (23-50/93)	4.9	Mu
Porosity	92	%
Water absorption coefficient (4h)	0.025	Kg/m ² Vh
Water absorption coefficient (4h)	0.01	Kg/m ² Vh
Sorption Moisture Content		
0	0	kg/m ³
50	4.72	kg/m ³
65	5.3	kg/m ³
80	6.6	kg/m ³
93	10.6	kg/m ³
97	11.5	kg/m ³
99	15.9	kg/m ³
99.99	51.9	kg/m ³
100	213	kg/m ³

4. Storage

Products containing **Spaceloft®** should be stored in a clean, dry, and protected environment.

If material has to be stored outdoors, it should be placed on pallets and thoroughly covered with a waterproof tarp or plastic sheeting.

Spaceloft® should be stored in its protective packaging until required. Prevent direct exposure to the weather.

5. Applications

Spaceloft® can be applied by mechanical direct fix, rail and combined adhesive / mechanical fixing in the following applications*

Wall Type	Suitability
Solid Clay Brick	✓
Solid Concrete	✓
Steel & Steel Frame	✓
Timber Frame	✓
Calcium Silicate brick	✓
Natural Stone	✓
Fabricated stone	✓

Floor Type	Suitability
Below Screed	✓
Floating Floor	✓

Roof	Suitability
Flat Roof	✓
Sloped roof	✓
Terrace	✓

Thermal Bridges	Suitability
Internal	✓
External	✓
Services	✓

* risk assessment should determine the requirement for a full vapour control layer or variable diffusion membrane

Spaceloft® is not intended to be used in an exposed environment without a protective finish.

Spaceloft® may be used in isolation or in combination with another thermal insulation

material according to space and performance restraints.

Spaceloft® can also be used as an effective thermal bridging treatment particularly where space is limited example window and door reveals, heads and boards.

In accordance with ETA 11_0471, when installed in line with best practice recommendations **Spaceloft**® is expected to perform for the life of the building or, at minimum **50 years**.

5.1. Thermal Performance

The $\lambda^{90/90}$ of **Spaceloft**® is 0.015W/mK.

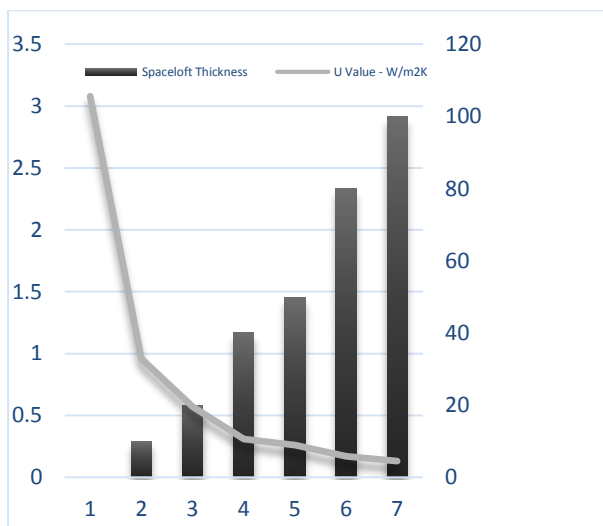

Typical U value per 10mm increment of **Spaceloft**® on solid concrete wall

Spaceloft® Thickness	Resistance m ² K/W
10mm	0.667
20mm	1.333
30mm	2.00
40mm	2.667
50mm	3.333
60mm	4.000
70mm	5.00
80mm	5.714
90mm	6.429
100mm	7.143

Thermal Resistance of Spaceloft® in 10mm layers

6. Site Safety Information

Spaceloft® containing products are delivered to site on pallets / in rolls with labels identifying the product name and dimensions.

Spaceloft® weighs approx. 1.5 kilos per m² of 10mm, according to the final composition more than one person may be required to lift.

It is recommended to wear a dust mask (P100/P3 filter) and eye protection when cutting. Cover rolls during transport through common areas of the building. Always observe local safety rules. Refer to the **Spaceloft**® SDS for additional safety information

Note: Spaceloft® dust is hydrophobic, use soap when washing to remove any dust. Work-wear can be laundered as normal.

7. Preparation

A competent building professional should be employed to install the **Spaceloft**® based solution.

A qualified electrician / plumber must be used to modify the position of any wiring / pipework.

The safe and appropriate ventilation of the property must not be negatively impacted by the installation of the insulation system.

The wall / thermal bridge area should be sound, clean, dry and free from biological contamination. Any potential for air or moisture leakage should be repaired before work commences. It may also be necessary to remove old wall coatings, particularly those containing organic materials before applying the upgrade solution. While **Spaceloft**® will accommodate minor wall or floor surface undulations a stabilising layer may be required to provide a sound fixing surface.

8. Fixing Instructions

Spaceloft® insulation, in panel or roll form should be mechanically fixed to the rail, frame or substrate with the appropriate fixings. Care should be taken to identify & locate load bearing sections for kitchen units, shelves or televisions before applying the insulation solution.

Spaceloft® is generally not suitable for adhesive fixing apart from small areas (shallow window reveals) and should not be subject to loading or unsupported foot traffic especially in roof applications.

Spaceloft® Blanket

Spaceloft® blanket can be cut accurately and cleanly with a sharp steel, heated or ceramic blade.

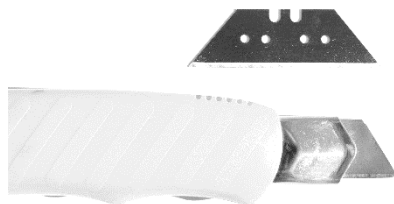

Tip! - Place a softwood panel under the **Spaceloft®** section to protect the knife blade during cutting



Ceramic & Heated Blade Cutting

To achieve the best quality finish apply light compression when cutting **Spaceloft®**.

8.1. Fixing – Internal Wall

Spaceloft® should be secured tightly to the substrate using appropriate mechanical fixings. The **Spaceloft®** layer should be butted tightly to ensure continuity of thermal performance and avoid thermal looping.

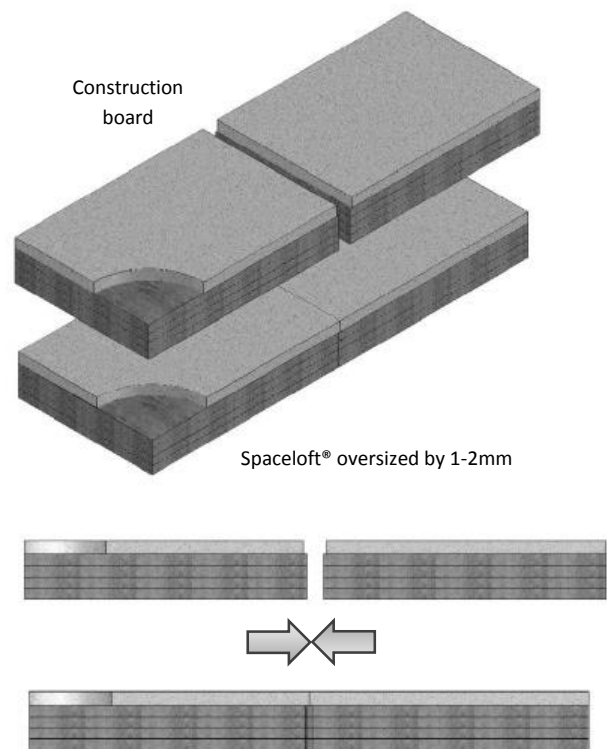

Tightly closed joints reduce air / vapour leakage

8.2. IWI - Fixing Types

Spaceloft® has excellent tensile strength however transverse tensile strength is not sufficient to support additional loading therefore should be mechanically fixed especially where perpendicular / transverse loading is required / expected.

The type and length of mechanical fixings should be selected according to local fire authority standards and should be of polymer and or stainless steel construction to minimise point thermal bridging.



Drilling Spaceloft® - 40mm layer

Spaceloft® can be stapled to wooden substrates such as studs and rafters. (stainless steel staples preferable)

Tip! - Use a large diameter washer (20 – 30mm) to avoid pull through when direct screwing Spaceloft® to substrates.

Type	Image
Panel / Blanket	
Blanket	

Mounting	Fixings / 2.88m ² Panel*
Timber Batten	20
Steel Rails	20
Solid Wall	12

* Approximate requirements – consult system designer for site specific recommendations

Important! If the system is installed with a vapour control layer any penetrations should be repaired using a suitable treatment.

Items used to fix Spaceloft® panels but outside of the scope of this document include

- Air / Vapour control membrane
- Sealing compound
- Stainless steel screws / fixings or plastic fixings
- Fixing rails

9. IWI Decoration and Finishing

Spaceloft® is traditionally finished with a robust impact layer such as

- Gypsum Panel
- Wood Fibre Board
- Magnesium Silicate Board
- Calcium Silicate Board
- Cement Fibre board

It is possible to direct plaster the following finishes on to Spaceloft® (surface priming may be required)

- Lime
- Gypsum
- Clay
- Sand & Cement
- Polymer modified coating

The selected finish will require a mechanically fixed reinforcing mesh to support the weight of the render or plaster. It is recommended to prepare a test area in advance, consult with system designer first.



The thickness of the primer / finishing coat should follow manufacturers' recommendations, it is strongly advisable that the installer test an area of Spaceloft for adhesion / drying time before addressing the main work area.



10. Floor Insulation

Spaceloft® can provide an ultra-effective upgrade for floor, flat roof and terrace areas where space is limited. Examples include the thermal upgrade of solid stone or concrete floors in existing buildings where door threshold heights are fixed and situations where incorrect level build-up has reduced the height available for traditional floor insulations.

The use of **Spaceloft®** can also negate the need to break out an existing concrete slab to increase available depth.

Spaceloft® is compatible with floating and wet screed floors in domestic and lightly trafficked areas. **Spaceloft®** is generally not suitable for heavy duty industrial or commercial applications.

Spaceloft® should not be subjected to large point loading, consult with your local **Spaceloft®** agent for further guidance.

10.1 Wet Screeds

Before starting, ensure floor slab is level and free from dust & debris.

- *A damp proof membrane (DPM) should be placed on the existing slab as necessary.*
- *Place **Spaceloft®** layer directly onto slab / DPM, ensure parallel joints are butted tightly.*
- *Use a steel, ceramic or heated blade to cut **Spaceloft®** to fit.*
- *Use **Spaceloft®** as an effective rising edge insulation to ensure continuity of the floor to wall insulation layer.*
- *Avoid damage to **Spaceloft®** layer during installation, use of a temporary protective trafficking layer is recommended.*
- *Cross lap alternate layers of **Spaceloft®***
- *Cover **Spaceloft®** layer with a separating layer to prevent screed contact and liquid runoff.*
- *The separating layer should cover 100% of the **Spaceloft®** blanket, overlap joints by min. 150mm and secure with an appropriate jointing tape.*
- *Carry membrane up walls – min 100mm, securing to wall or to IWI system vapour barrier (if possible) with appropriate sealing tape or sealant.*
- *Concrete or thin screeds can be applied as per manufacturers' instructions.*

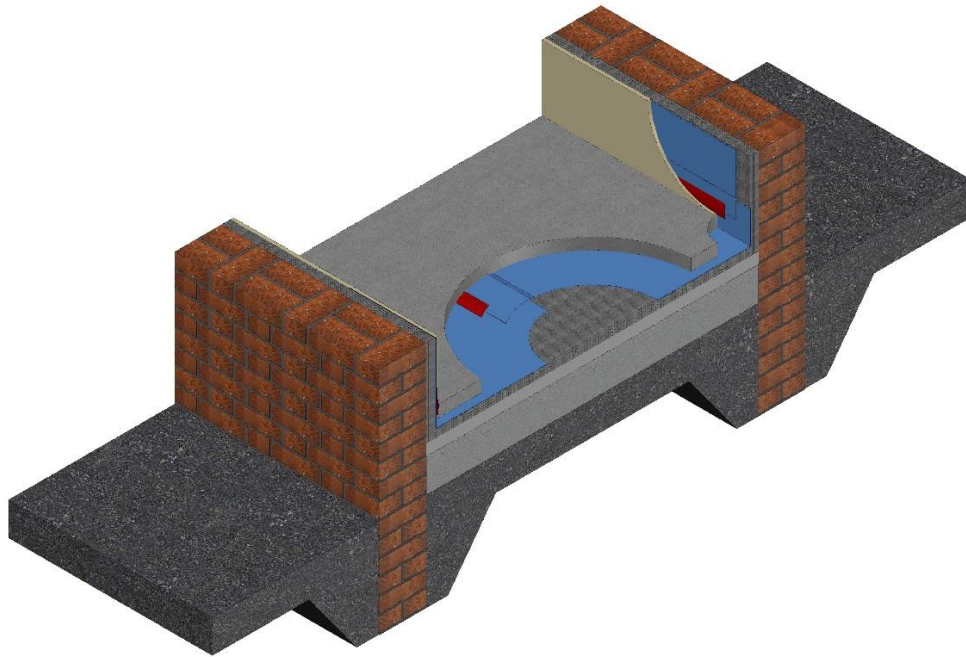

Spaceloft® on concrete slab integrated to internal wall insulation system

10.2 Floating Floor

The installation follows that of a wet screed however a sealed air tight membrane should be used instead of a separating layer to prevent dust generated during installation from migrating into the floor covering. This membrane should be brought up wall and sealed using an appropriate tape / sealant.

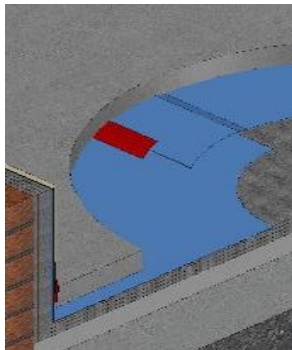

Overlap membrane by 150mm & tape

10.3 Flat Roof & Terrace Systems

Spaceloft® can be used as the primary, composite or secondary insulation in flat roof, balcony and terrace upgrades. As these applications are site specific, guidance should be sought from your local **Spaceloft®** partner.

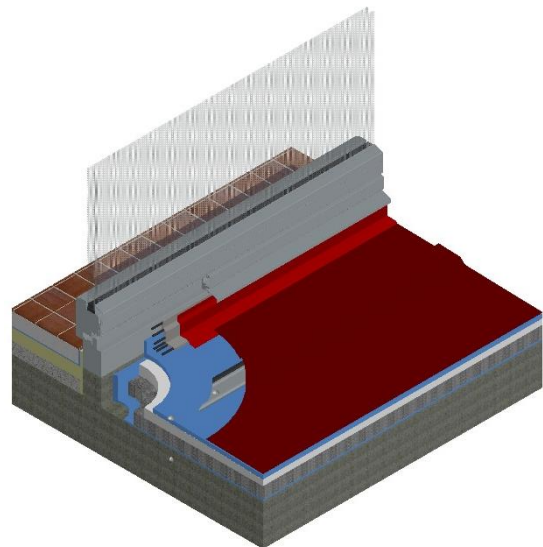

11. Thermal Bridging Treatments

Spaceloft® can be used to reduce surface condensation at window and door openings where conventional insulations would obscure the window frame or provide insufficient thermal resistance.

A 10mm layer of **Spaceloft®** is typically sufficient to increase the surface temperature factor f_{Rsi} above the critical limit (0.75) necessary to avoid surface condensation.

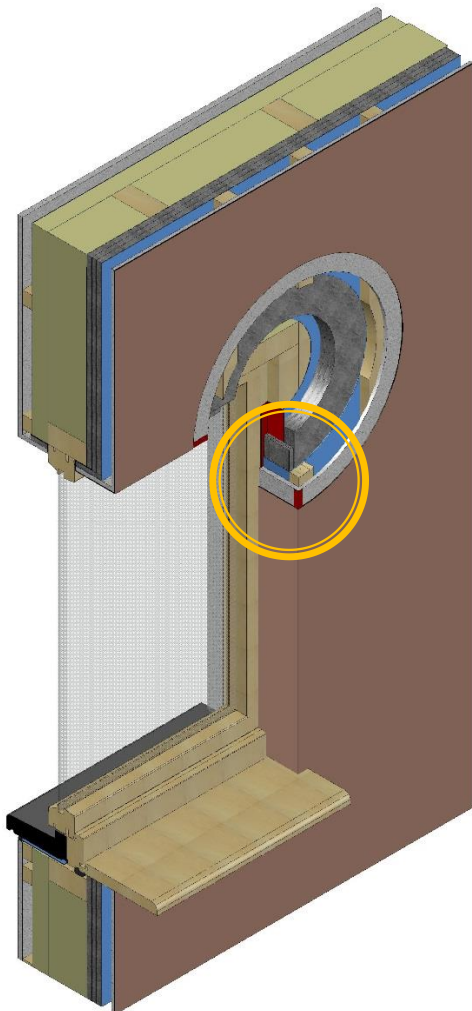

Typical Detail of Window Opening

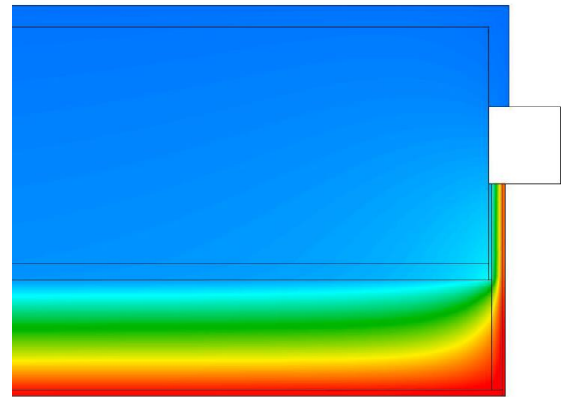

Temperature 0 20 °C

Isotherm of window opening treated with **Spaceloft®** 10mm

Linear thermal transmittance

$\Psi = 0.090 \text{ W/mK}$	reveal (DEAP)	$\Psi = 0.094 \text{ W/mK}$	frame (PHPP)
-----------------------------	------------------	-----------------------------	-----------------

Temperature factor

$$f_{Rsi} = 0.880$$

A 10mm layer of **Spaceloft®** 500mm long is sufficient to limit the thermal bridge at adjoining solid apartment walls.

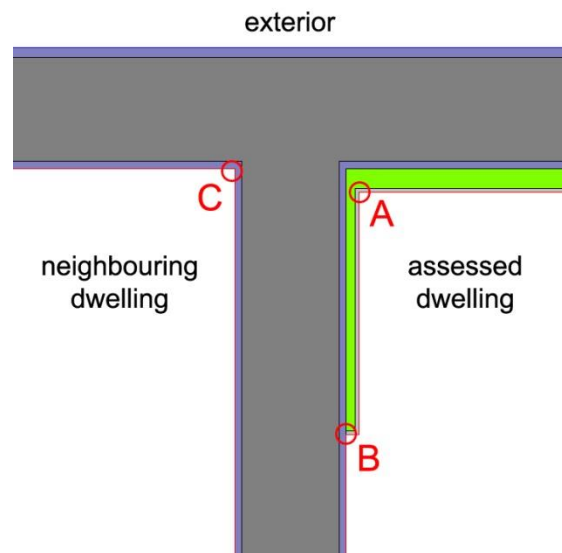

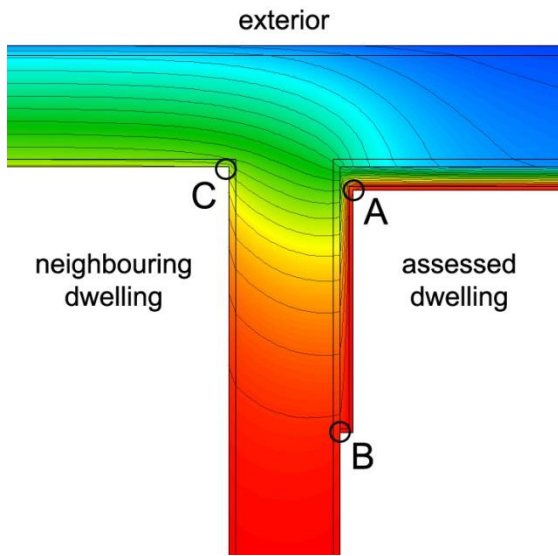

Thermal Bridge at treated & non treated properties

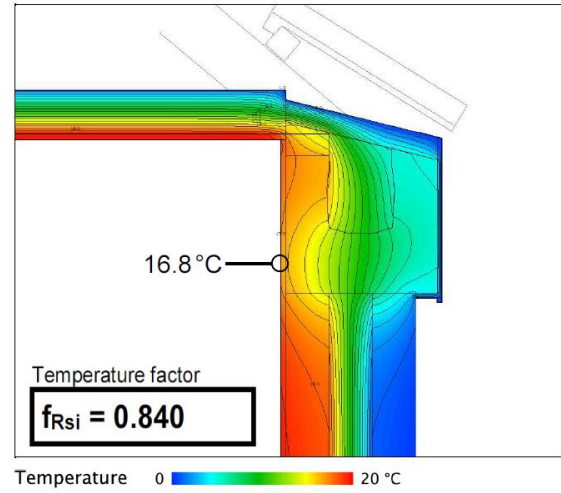

Solid Concrete Gutter Detail – 10mm & 20mm Spaceloft® applied externally

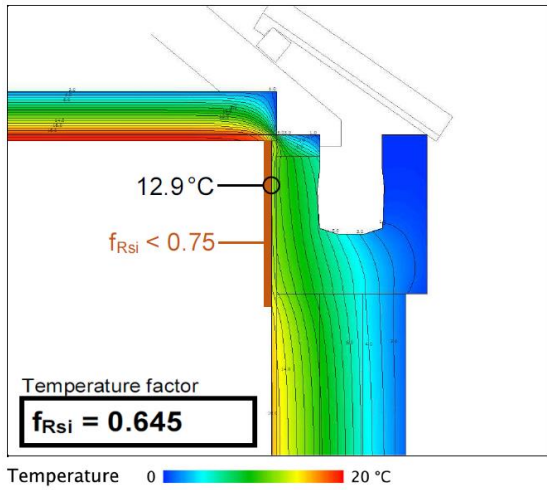

Solid Concrete Gutter Detail – Before

12.Detail Drawings

12.1. Floating Floor – Dry

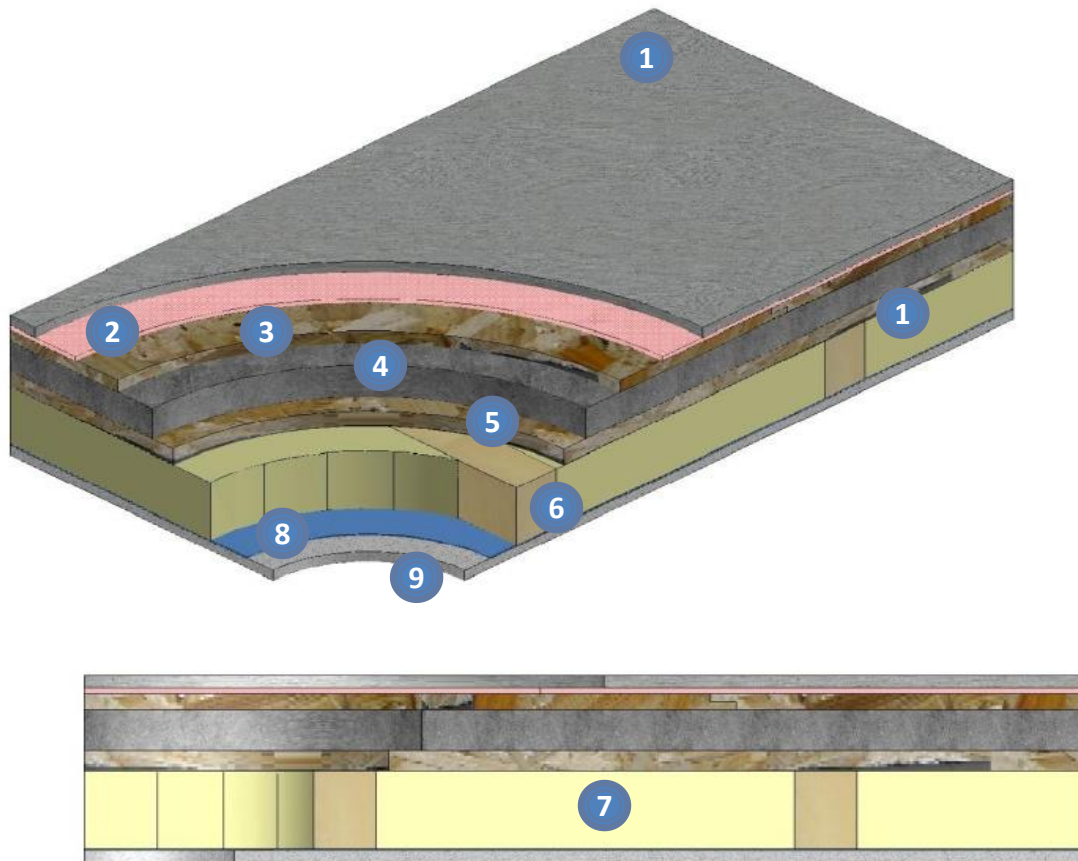

Position	Description
1	Floor Finish
2	Separating Layer
3	Load Distribution Layer
4	Spaceloft® 40mm
5	Flooring Timber
6	Floor Framework
7	Additional Insulation between studs
8	Fixed or Variable Vapour Control Layer
9	Construction Board

12.2. Floating Floor – Wet

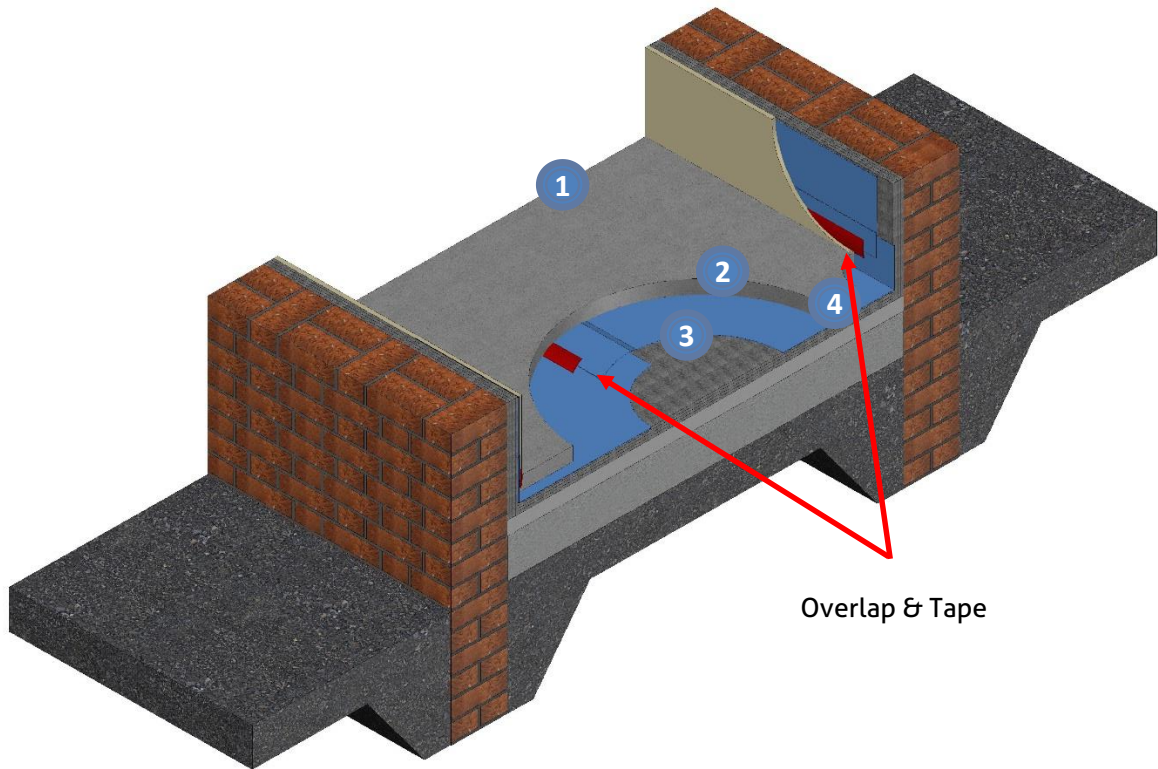

Position	Description
1	Floor Screed
2	Separating Layer – Taped & Returned
4	Spaceloft® 40mm Cross Lapped
5	Floor Slab

12.3. Ventilated Facade – Timber Frame Construction

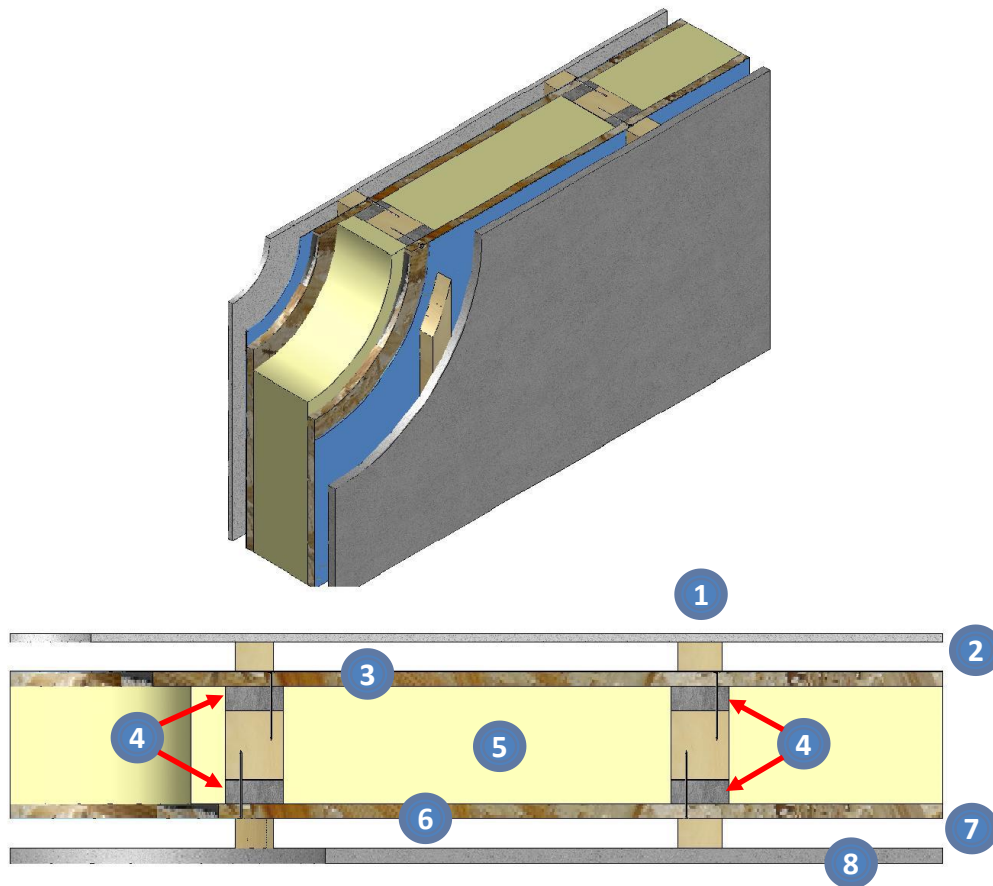

Position	Description
1	External Cladding
2	Battened Air Cavity
3	Structural panels
4	Thermal Bridging Gaskets – Spaceloft® 20mm
5	Primary Insulation Layer
6	Structural Panels
7	Battened air Cavity
8	Construction Board

12.4. Internal Wall Insulation – Wet Finish

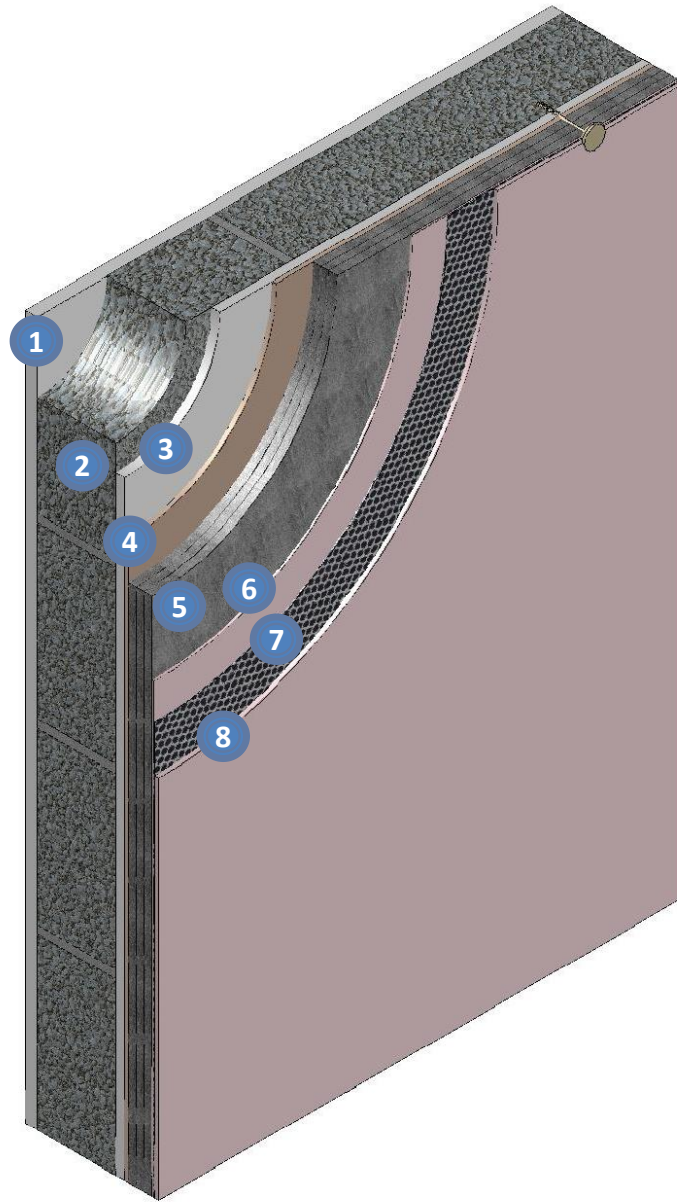

Position	Description
1	External Plaster
2	Brick / Stone / Concrete Wall
3	Levelling & Stabilisation Plaster (Optional)
4	Adhesive Mortar (5mm) - optional
5	Spaceloft® (prelaminated or individual layers)
6	Base Coat Plaster
7	Mechanical Fixings & Reinforcing mesh / Construction Panel
8	Plaster & Decorative finish

12.5. Internal Wall Insulation on Studs

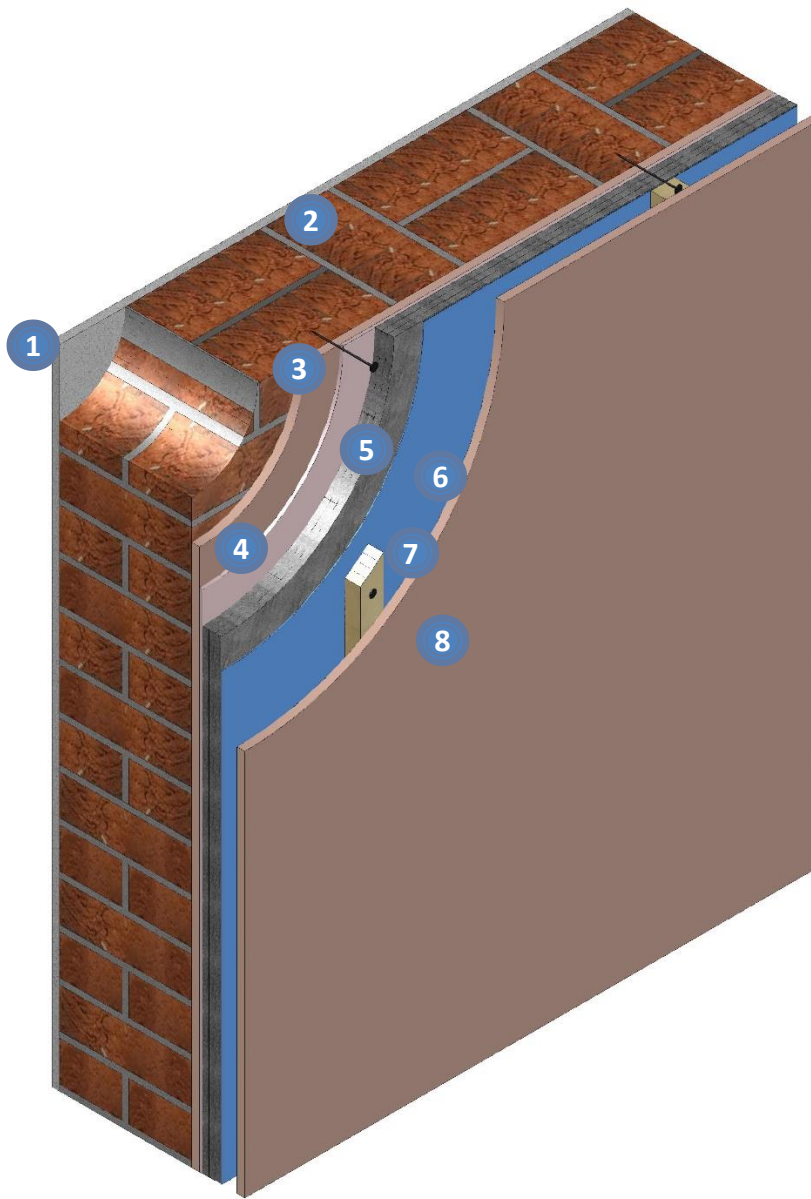

Position	Description
1	External Plaster
2	Brick / Stone / Concrete Wall
3	Levelling & Stabilisation Plaster (Optional)
4	Adhesive Mortar – (Optional)
5	Spaceloft® (prelaminated or individual layers)
6	Air Control + Fixed or Variable Vapour Control Layer
7	Timber Batten (Optional)
8	Construction Board & Decorative finish

12.6. Ceiling Insulation

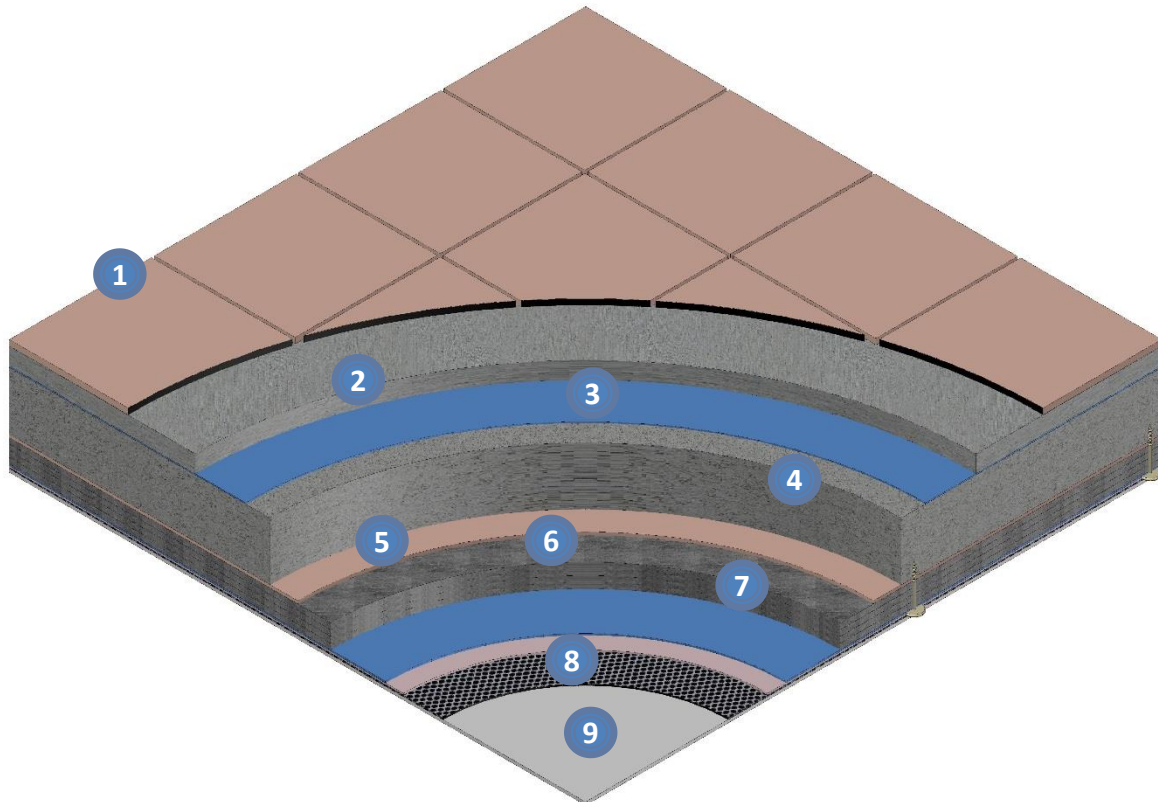

Position	Description
1	Tiles & Weathering System
2	Floating Screed
3	Waterproofing membrane
4	Concrete Deck
5	Adhesive Layer (5mm)
6	Spaceloft® (prelaminated or individual layers)
7	Levelling & Stabilisation Plaster
8	Reinforcing Mesh & Mechanical Fixings / Construction Panel
9	Decorative Finish

12.7. Thermal Bridges at Openings

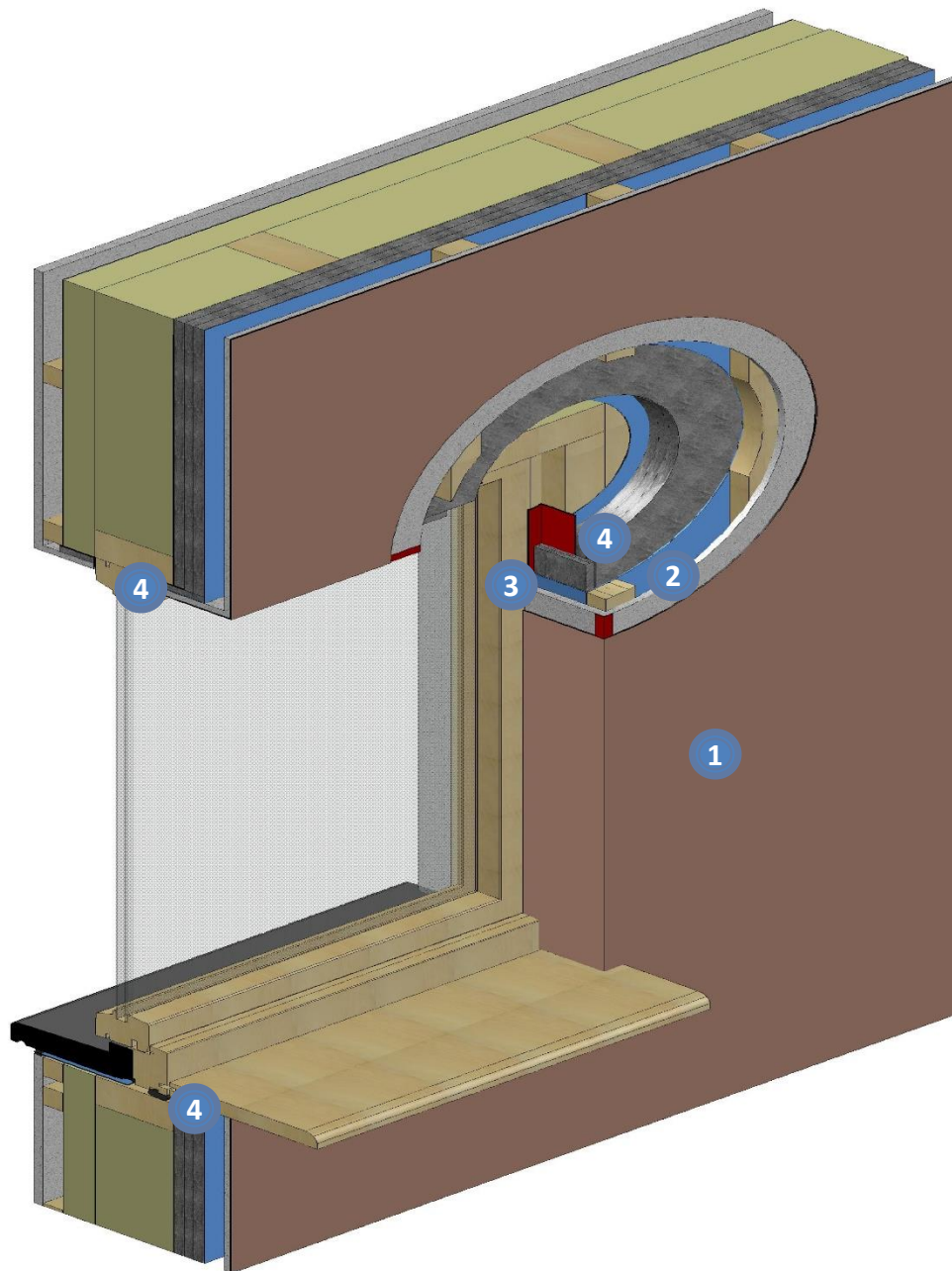

Position	Description
1	Decorative Finish
2	Construction Board
3	Air / Vapour Control Layer
4	Spaceloft® 10-20mm

10 Fire Behaviour

When correctly installed the **Spaceloft**® insulation component will be situated between the wall and the facing construction panel or finish. **Spaceloft**® will not contribute to the development of a fire or present a smoke or toxic smoke hazard as a fire develops.

Spaceloft is classified as Euroclass C, S1,D0

11 Proximity of flues and Appliances

Where the **Spaceloft**® assembly is installed in close proximity to flue pipes or heat producing appliances, the relevant provisions of the national building regulations should be met.

Spaceloft® is classified as Euroclass C, s1, d0, thermal insulation. Spaceloft's maximum operating temperature is 200 °C however expert guidance should be sought from your local **Spaceloft**® partner if detailing for use above normal construction temperatures.

12 Materials in Contact – Wiring

As with other forms of insulation, de-rating of electrical cables should be considered where **Spaceloft**® restricts the air cooling of electrical cables. Contact with **Spaceloft**® does not negatively affect PVC insulated cables.

13 Infestations

Use of **Spaceloft**® does not promote infestation; care should be taken to seal all cavities to prevent habitation of vermin or insects.

Spaceloft® is extremely hydrophobic and does not provide a source of nutrition for mould.

14 Wall Mountings

The fixation of items other than lightweight objects should be according to professional advice and is not covered by this advice document.

15 Maintenance

The systems, if damaged during use can be removed and replaced. It is advised to inform those responsible for the upkeep of the system how to maintain the vapour permeability of the completed solution to avoid use of unsuitable coatings on the building fabric.

16 Durability

When installed in accordance with the condition outlined in ETA 11_0471 **Spaceloft**® is expected to perform for the life of the building or at least 50 years.

17 Emissions

Spaceloft® meets the highest requirements of the interior emissions M1 test (Finland)

Spaceloft® does not contain any resins, binders or performance enhancing gasses which may be released during service.

18 Environmental

An Environmental Product Declaration (EPD) for Spaceloft is available on request.

Aspen Aerogels operates a sustainable supply chain management and responsible sourcing system.

19 Additional Information

Additional information such as WUFI assessments, case studies, details and technical information not contained in this document may be obtained by emailing info@aerogel.com